

Europäisches Patentamt
European Patent Office
Office européen des brevets



(11) EP 0 860 708 A2

(12) EUROPEAN PATENT APPLICATION

(43) Date of publication:
26.08.1998 Bulletin 1998/35

(51) Int. Cl.⁶: G01S 1/00

(21) Application number: 98103057.0

(22) Date of filing: 21.02.1998

(84) Designated Contracting States:
AT BE CH DE DK ES FI FR GB GR IE IT LI LU MC
NL PT SE
Designated Extension States:
AL LT LV MK RO SI

- Yung, Kar W.
Signal Hill, CA 90806 (US)
- Novak, John I. III
Signal Hill, CA 90806 (US)
- Goliff, William
Signal Hill, CA 90806 (US)

(30) Priority: 21.02.1997 US 803935

(71) Applicant:
Hughes Electronics Corporation
El Segundo, California 90245-0956 (US)

(74) Representative:
Witte, Alexander, Dr.-Ing. et al
Witte, Weller, Gahlert, Otten & Steil,
Patentanwälte,
Rotebühlstrasse 121
70178 Stuttgart (DE)

(72) Inventors:
• Chang, Donald C.
Thousand Oaks, CA 91360 (US)

(54) Method and system for determining a position of a transceiver unit utilizing two-way ranging in a polystatic satellite configuration including a ground radar

(57) A method and system for determining the position of an object (12), such as an aircraft, utilizes two-way ranging with a polystatic satellite configuration and ground radar (13). A ground transceiver (13) at a first known location provides a bidirectional communication path between the ground transceiver (13) and the object (12) wherein the ground transceiver (13) transmits a first ranging signal to the object (12) and the object (12) transmits a second ranging signal to the ground transceiver (13) in response to the first ranging signal. A first communication transceiver (11) at a second known location provides a first unidirectional communication path (R₃) between the first communication transceiver (11) and the object (12) wherein the first communication transceiver (11) performs one of transmitting a third ranging signal to the object (12) and receiving a third ranging signal from the object (12) in response to the first ranging signal. A second communication transceiver (11) is arranged at a third known location for providing a second unidirectional communication path (R₄) between the second communication transceiver (11) and the object (12) wherein the second communication transceiver (11) performs one of transmitting a fourth ranging signal to the object (12) and receiving a fourth ranging signal from the object (12) in response to the first ranging signal. A signal processor (13, 14, 16) determines a first, second and third path length, and determines the position of the object (12) based on the

first, second and third known locations and the first, second and third path lengths.

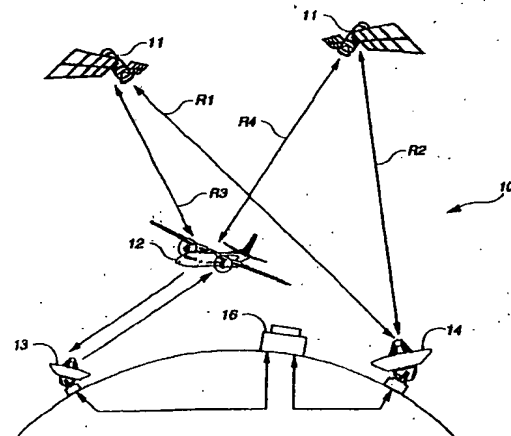

Fig. 1

EP 0 860 708 A2

Description

Cross-Reference to Related Applications

This application is related to co-pending application entitled "Method and System For Determining a Position of a Target Vehicle Utilizing Two-Way Ranging," filed Feb. 21, 1997 and is further related to co-pending application entitled "Method And System For Determining A Position Of A Transceiver Unit Utilizing Two-way Ranging in a Polystatic Satellite Configuration," filed Feb. 21, 1997.

Technical Field

This invention relates to methods and systems for determining a position of a transceiver unit, such as those employed on an aircraft, utilizing two-way ranging in a polystatic satellite configuration including a ground radar.

Background Art

Current Automatic Dependent Surveillance (ADS) technology, such as Global Positioning System (GPS), Wide Area Augmentation System (WAAS) or GLO-NASS, provides positioning information utilizing satellite transmissions. For example, the GPS, developed and deployed by the U.S. Department of Defense, consists of 24 satellites orbiting the earth twice a day at an altitude of 12,000 miles, as well as five ground stations to monitor and manage the satellite constellation. Using atomic clocks and location data, GPS satellites transmit continuous time and position information 24 hours a day to a GPS receiver, which listens to three or more satellites at once to determine the user's position. By measuring the time interval between the transmission and the reception of a satellite signal, the GPS receiver calculates the distance between the user and each satellite, and then uses the distance measurements of at least three satellites to arrive at a position.

Such systems, however, utilize one-way ranging in which an accurate, synchronized clock is required at each station. Any synchronization error or error regarding the location of one of the satellites results in an error in the determined position of the target vehicle. Thus, there is a need to provide very accurate position and velocity information with a high degree of integrity and reliability.

Disclosure Of The Invention

It is thus a general object of the present invention to provide a method and system for determining a location of an object with a high degree of integrity and reliability utilizing two-way ranging in a polystatic satellite configuration to derive independent estimates of the transceiver's state vectors including position and velocity.

In carrying out the above object and other objects, features, and advantages of the present invention, a method is provided for determining position of an object. The method includes the steps of transmitting a first ranging signal from a first known ground location to the object and transmitting a second ranging signal in response to the first ranging signal to the first known ground location. The method also includes the steps of transmitting a third ranging signal in response to the first ranging signal to a second known location and transmitting a fourth ranging signal in response to the third ranging signal to a third known location. The method further includes the step of determining a first delay corresponding to a time difference between transmission of the first ranging signal and receipt of the second ranging signal. The method also includes the step of determining a second delay corresponding to a time difference between transmission of the first ranging signal and receipt of the third ranging signal. Still further, the method includes the step of determining a third delay corresponding to a time difference between transmission of the first ranging signal and receipt of the fourth ranging signal. The method finally includes the step of determining the position of the object based on the first, second, and third known locations and the first, second and third delays.

In further carrying out the above object and other objects, features, and advantages of the present invention, a system is also provided for carrying out the steps of the above described method. The system includes a ground transceiver at a first known ground location for providing a bidirectional communication path between the ground transceiver and the object wherein the ground transceiver transmits a first ranging signal to the object and the object transmits a second ranging signal to the ground transceiver in response to the first ranging signal. The system also includes a first communication transceiver at a second known location for providing a first unidirectional communication path between the first communication transceiver and the object wherein the first communication transceiver performs one of transmitting a third ranging signal to the object and receiving a third ranging signal from the object in response to the first ranging signal. The system further includes a second communication transceiver at a third known location for providing a second unidirectional communication path between the second communication transceiver and the object wherein the second communication transceiver performs one of transmitting a fourth ranging signal to the object and receiving a fourth ranging signal from the object in response to the first ranging signal. Finally, the system includes a signal processor for determining a first path length corresponding to a first time length of the bidirectional communication path, determining a second path length corresponding to a second time length of the first unidirectional communication path, determining a third path length corresponding to a third time length of the sec-

ond unidirectional communication path, and determining the position of the object based on the first, second, and third known locations and the first, second, and third path lengths.

The above object and other object, features and advantages of the present invention are readily apparent from the following detailed description of the best mode for carrying out the invention when taken in connection with the accompanying drawings.

Brief Description Of The Drawings

FIGURE 1 is a diagrammatic representation illustrating a communication system employing the method and apparatus of the present invention;

FIGURE 2 is a block diagram of the aircraft segment and the ground segment included in the system shown in Figure 1;

FIGURE 3 is a block diagram of a preferred transmitter and a preferred receiver for the traffic controller station used in the system of Figure 1; and

FIGURE 4 is a block diagram of a preferred transmitter and a preferred receiver for a vehicle in the system of Figure 1.

Best Modes For Carrying Out The Invention

Referring first to Figure 1, a communication system 10 with a typical geometry for practicing the present invention is diagrammatically illustrated. The present invention is particularly suited for determining the position of an aircraft during Category I landings, as described with reference to the preferred embodiment. However, the present invention is also suitable for tracking other objects, such as a surface ground vehicle. There are typically two communication satellites 11 within the field of view of an aircraft 12 when aircraft 12 is in a final landing phase. Aircraft 12 communicates with at least one traffic controller station 16 via a ground radar 13 and/or a satellite ground station 14. Communication satellites 11 are preferably in multiple planes using Low Earth Orbit (LEO) satellite constellations and/or Medium Earth Orbit (MEO) satellite constellations such as Iridium, Intermediate Circular Orbit (ICO), Teladesic and Globalstar. In addition, a Geosynchronous Earth Orbit (GEO) satellite constellation may also be used in conjunction with the LEO and/or MEO satellite constellations. The planned ICO configuration with ten to twelve satellites in two planes is adequate to implement the position location and tracking of aircraft 12.

The stationary ground radar 13, such as a Secondary Surveillance Radar (SSR), provides better accuracy in determining the position of the aircraft 12 since it is at a fixed known location on ground. Stationary radar 13

interrogates a transceiver (not shown) on board aircraft 12 with a pulsed ranging signal. Aircraft 12 then responds by transmitting a return pulsed ranging signal with a time stamp back to stationary ground radar 13, thus utilizing two-way ranging.

To obtain more accuracy and flexibility, the present invention employs a polystatic configuration. A polystatic configuration consists of several transceivers at separated locations, which cooperate with each other. The transceivers may be stationary or moving. In a monostatic configuration, the forward and return ranging signals propagate through the same link. As such, the equal range locations of the measurement are confined to a spherical surface centered on the relay satellite position with a radius (range) equal to a distance between aircraft 12 and the relay satellite. By utilizing polystatic techniques, in which the forward and return ranging signals propagate through different satellites, the equal range locations of the measurement are confined to an ellipsoidal surface. The two foci are located at the satellite positions so that the sum of the distances between aircraft 12 and the two satellites 11 is a constant.

Thus, the interrogating signal initiated by stationary ground radar 13 also triggers aircraft 12 to regenerate additional ranging signals with respective time stamps for receipt by each of the communication satellites 11. Communication satellites 11 then forward the ranging signals to ground via satellite ground station 14, such as a Satellite Access Node (SAN).

Similarly, various ranging signals from satellite ground station 14 to aircraft 12 via communication satellites 11 trigger different responding signals from aircraft 12. The responding signals are forwarded back to ground in one of two ways: 1) only back to stationary ground radar 13 directly or 2) back to stationary ground radar 13 and each of the communication satellites 11. Preferably, traffic controller station 16 informs the aircraft 12 of which return link strategy to employ prior to initiation of the two-way ranging.

Traffic controller station 16 compares the received time stamps to the time at which the ranging signals were initiated on ground. Preferably, traffic controller station 16 is an Air Traffic Controller (ATC) facility having signal processing capability. Alternatively, the signal processing capability may be located at stationary ground radar 13 and/or satellite ground station 14. The lengths of the various paths are determined by calculating the difference between the received time stamps and the initiated time stamps of each of the ranging signals. Traffic controller station 16 then determines the location of aircraft 12 utilizing a triangulation calculation based on the lengths of the various paths, the position of stationary ground radar 13 and the ephemeris of communication satellites 11. ATC facility 16 will also relay the ground-validated position and velocity vectors to aircraft 12 for use by the pilot of aircraft 12.

The present invention may be utilized in conjunction

with GPS. When GPS signals are available, the GPS signals are used to derive the aircraft state vector which is then transmitted to traffic controller station 16, via communication satellites 11 and satellite ground station 14. Improved estimation of the aircraft state vectors is accomplished through data fusion of the two independent measurements, i.e, the GPS measurement and the two-way ranging measurement. The updated aircraft state vectors are then transmitted to aircraft 12.

The time stamps through various forward links arrive at aircraft 12 in different time slots. It is possible to allow fixed processing delays to multiplex the time stamps together, and then transmit the multiplexed ranging signal through different return links simultaneously or sequentially. However, it is also possible to transmit the multiplexed signal through a single return link to save return link space assets when needed. Similarly, the present invention is flexible enough to save forward link assets also. In addition, it is possible to use ICO satellites either as forward or as return link relays (not both) and to utilize other (GEO, MEO or LEO) mobile satellites as the complementary link relays.

The positions in space of communication satellites 11 are known so that the ranges R_1 and R_2 between each of communication satellites 11 and satellite ground station 14 are known. However, ranges R_1 and R_2 can be calibrated over time to obtain a more accurate measurement. The links R_3 and R_4 are then employed to determine the state vectors by two-way ranging from satellite ground station 14 to aircraft 12. The time difference between the time at which the ranging signal is transmitted by satellite ground station 14 and the time at which the responding ranging signal from aircraft 12 is received by satellite ground station 14 is used in determining ranges R_3 and R_4 .

Turning now to Figure 2 there is shown simplified block diagrams of both an aircraft segment 18 and a ground segment 20 of the present invention. Aircraft segment 18 includes a conventional GPS receiver 22 for receiving GPS signals from a GPS satellite 24 via an antenna 25. GPS receiver 22 sends a position signal to a conventional Extended Kalman-Filter (EKF) 26 which tracks the position signal as a state vector. An optional input 27 to EKF 26 is a signal from an Inertial Navigation System (INS), such as a conventional mechanical gyro system which monitors the distance traveled by aircraft 12 from a predetermined position.

Aircraft 12 receives ranging signals from communication satellites 11 and stationary ground radar 13 via a second antenna 28. Second antenna 28 is preferably a retrodirective antenna implemented with a Butler matrix, a low-profile digital beam former, and Wavelet-based Finite-Impulse-Response (WFIR) signal processing. The retrodirective antenna measures the direction of the received signal from communication satellite 11 and stationary ground radar 13 and automatically transmits the return signal back accordingly. The Butler matrix implements a Fourier transform forming a set of nearly

orthogonal beams covering the field-of-view and is a relatively inexpensive approach to realizing a retrodirective antenna. The low-profile digital beam former array lends itself to a thin conformal array configuration which is preferred for aircraft installation. Optionally, a tracking antenna can be used in place of the retrodirective antenna which consists of either an electronically or mechanically steered antenna driven by a monopulse, step-scanned, or conically-scanned tracking loop.

In order to utilize polystatic techniques in the present invention, a digital implementation of the Butler matrix is also required, such as a conjugate gradient digital beam former, in order to memorize the phase gradients of signals from various communication satellites 11, i.e, the direction of the incoming signals, and to apply proper phase conjugations to the outgoing signals so that the outgoing signals are directed to appropriate communication satellites 11.

The data between aircraft segment 18 and ground segment 20 can be combined with the unique ranging code signal in one of several ways: 1) Overlaying a Auslander-Barbano (AB) Code Division Multiple Access (CDMA) tracking code on the communication link channels as low-level Additive White Gaussian Noise (AWGN), thermal noise-like signals which slightly raise the thermal noise floor; 2) Modulating the communication data with the AB CDMA ranging code and sent as a single waveform, as shown in Figure 3; and 3) Separating the ranging links from data links. In the preferred embodiment shown in Figure 3, ATC facility 16 transmits data which is modulated by a WFIR waveform with a unique AB ranging code assigned to each aircraft being tracked in the particular time slot. WFIR modulation enables the ranging signals to have variable resolution in addition to variable length. The waveform specifically provides a means to transmit a relatively wide-band WFIR ranging waveform over a group of narrow-band communication satellite channels, simultaneously or sequentially, and supports simultaneous ranging/doppler measurements and data demodulation.

The two-way ranging data 30 is sent to ground segment 20 via stationary ground radar 13 and satellite ground station 14. Two-way ranging data 30 is used to drive a dual alpha-beta (α - β)/EKF tracking loop 32 wherein the fast α - β loop tracks the AB CDMA code in communication coordinates, and the slow EKF tracks the target aircraft in Earth Centered Inertial (ECI) coordinates to provide a unique preferred tracking architecture with low-complexity, high accuracy, and high integrity with fast-response valid-track metrics, and the ability to track out total-electron-content (TEC) induced waveform transmission range and doppler offsets.

The α - β loop is a relatively fast pair of time and frequency tracking loops which measure and smooth the received two-way ranging signals during each access. The four dimensional state vector Z for the α - β loop consists of the timing offset, time drift, frequency offset and frequency drift. Time drift refers to clock drift whereas

frequency offset refers to doppler shift due to link motion plus TEC. The state vector X for the EKF loop has eleven components consisting of the three-dimensional ECI position coordinates, velocity, acceleration, and the ranging plus doppler coordinates associated with ionospheric TEC effects.

Based on the α - β observation data from a previous access, the EKF loop predicts ahead its state X_k at the state transition time k^*T , where T is the update interval for the EKF. This state is mapped into the corresponding predicted state Z_k of the α - β loop. During the access slot time ΔT , the α - β loop generates a smoothed state Z_k which is then used by the EKF to smooth the predicted state to generate the smoothed state X_k . This allows the EKF to predict ahead the state X_{k+1} at $(k+1)^*T$. This procedure is repeated for the next access.

The predicted state vector from the dual α - β /EKF tracking loop 32 and the estimated state vector 34 from aircraft 12 are transmitted to a fusion processor 36 which performs data fusion and validation between the two independent measurements to obtain an improved state vector estimation. Fusion processor 36 also receives other terrestrial based data 37, such as position of stationary ground radar 13, position of satellite ground station 14, and position of communication satellites 11. The improved state vector estimation is forwarded to ATC facility 16 which then transmits this information to aircraft 12. The improved state vector estimation 38 received by aircraft 12 is processed by EKF 26 to generate a new state vector.

Referring now to Figure 3, additional details of the receiver and transmitter used in traffic controller station 16 are shown comprising a transmitter 40 and a receiver 42. Satellite ground station 14 transmits data which is modulated by a wavelet-based finite impulse response (WFIR) waveform with a unique AB ranging code assigned to each aircraft 12 being tracked in the access time slot. The TDMA data to the targeted aircraft is modulated by the N-chip AB code sequence, unsampled by the WFIR sample rate M , and added with signals to other aircraft sharing the same access slot. The summed output is filtered by a wideband WFIR filter with overlaid envelope of the AB ranging waveforms. A bank of narrowband WFIR filters channelizes the wideband waveform into a set of narrowband waveforms which are compatible with the satellite communication channels such as ICO.

The receive processing at satellite ground station 14 is shown at 42. The baseband signal from the digitizer, shown as an analog-to-digital (A/D) function and an in-phase-quadrature (I/Q) function which may be combined is detected by a bank of narrowband (NB) WFIR filters matched to the ICO communication channels. The outputs are used to perform reconstruction of the wideband WFIR ranging signal for each aircraft. This reconstructed wideband WFIR waveform is then detected by on-time, early, and late correlators. The ranging time and data from each aircraft is recovered by

separate processing which performs the AB CDMA despreading, acquisition, tracking, time recovery, and data recovery.

As best shown in Figure 4, the aircraft receiver/transmitter 44 preferably includes a retrodirective antenna 46. A Butler matrix, low profile digital beam form (DBF), and WFIR signal processing are preferably employed. The retrodirective antenna 46 measures the direction of the received signal from the satellite 11, and automatically transmits the return signal back to the appropriate satellite 11. The Butler matrix implements a Fourier transform forming a set of nearly orthogonal beams covering the field of view, and has been proven to be a relatively inexpensive approach to realize a retrodirective antenna. The low profile DBF array lends itself to a thin conformal array configuration which is preferred for aircraft installation. The implementation technique eliminates the need for an expensive tracking antenna on the aircraft which usually consists of either an electronically or a mechanically steered antenna driven by a monopulse, step-scanned, or conically-scanned tracking loop.

The principles of the present invention are utilized by an aircraft in a final approach and landing phase. However, the method and system can be extended to air space having a high density of traffic and covered by existing S-band secondary surveillance radars. The present invention compliments ADS techniques based on Global Navigation Satellite System (GNSS) using GPS and/or Glonass systems. However, this invention will function without ADS.

While the best modes for carrying out the invention have been described in detail, those familiar with the art to which this invention relates will recognize various alternative designs and embodiments for practicing the invention as defined by the following claims.

Claims

1. A method for determining a position of an object utilizing two-way ranging, comprising the steps of:

transmitting a first ranging signal from a first known location (13) on ground to the object (12);
 transmitting a second ranging signal to the first known ground location (13) in response to the first ranging signal;
 transmitting a third ranging signal to one of the object (12) and a second known location different from the first known ground location (13) in response to the first ranging signal;
 transmitting a fourth ranging signal to one of the object (12) and a third known location different from the first known ground location (13) and the second known location in response to the first ranging signal;
 determining a first delay corresponding to a

- time difference between transmission of the first ranging signal and receipt of the second ranging signal;
determining a second delay based on the third ranging signal;
determining a third delay based on the fourth ranging signal; and
determining the position of the object (12) based on the first, second, and third known locations and the first, second and third delays. 10
2. The method of claim 1, characterized in that transmitting the third ranging signal includes transmitting the third ranging signal to the second known location, wherein transmitting the fourth ranging signal includes transmitting the fourth ranging signal to the third known location, wherein determining the second delay includes determining the second delay corresponding to a time difference between transmission of the first ranging signal and receipt of the third ranging signal, and wherein determining the third delay includes determining the third delay corresponding to a time difference between transmission of the first ranging signal and receipt of the fourth ranging signal. 15 20
3. The method of claim 1, characterized in that transmitting the third ranging signal includes transmitting the third ranging signal to the object (12) and in that transmitting the fourth ranging signal includes transmitting the fourth ranging signal to the object (12), the method further comprising:
transmitting a fifth ranging signal to one of the first known ground location (13) and the second known location from the object (12) in response to the third ranging signal; and
transmitting a sixth ranging signal to one of the first known ground location (13) and the third known location from the object (12) in response to the fourth ranging signal. 25 30 35 40
4. The method of claim 3, characterized in that transmitting the fifth ranging signal includes transmitting the fifth ranging signal to the first known ground location (13) and in that transmitting the sixth ranging signal includes transmitting the sixth ranging signal to the first known ground location (13). 45
5. The method of claim 3, characterized in that transmitting the fifth ranging signal includes transmitting the fifth ranging signal to the second known location and in that transmitting the sixth ranging signal includes transmitting the sixth ranging signal to the third known location. 50
6. A system for determining a position of an object (12) utilizing two-way ranging, comprising:

- a ground transceiver (13) at a first known location for providing a first bidirectional communication path between the ground transceiver (13) and the object (12) wherein the ground transceiver (13) transmits a first ranging signal to the object (12) and the object (12) transmits a second ranging signal to the ground receiver (13) in response to the first ranging signal;
a first communication transceiver (11) at a second known location for providing one of a second bidirectional communication path (R_3) and a first unidirectional communication path between the first communication transceiver (11) and the object (12) wherein the first communication transceiver (11) performs one of transmitting a third ranging signal to the object (12) and receiving a third ranging signal from the object (12) in response to the first ranging signal;
a second communication transceiver (11) at a third known location for providing one of a third bidirectional communication (R_4) and a second unidirectional communication path between the second communication transceiver (11) and the object (12) wherein the second communication transceiver (11) performs one of transmitting a fourth ranging signal to the object (12) and receiving a fourth ranging signal from the object (12) in response to the first ranging signal; and
a signal processor (13, 14, 16) for determining a first path length based on the first bidirectional communication paths (R_3), determining a second path length based on one of the second bidirectional communication path (R_4) and first unidirectional communication path, determining a third path length based on one of the third bidirectional communication path and second unidirectional communication path, and determining the position of the object (12) based on the first, second and third known locations and the first, second and third path lengths.
7. The system of claim 6, characterized in that the first communication transceiver (11) provides the first unidirectional communication path (R_3) from the object (12) to the first communication transceiver (11) so that the object (12) transmits the third ranging signal to the first communication transceiver (11) in response to the first ranging signal and in that the second communication transceiver (11) provides the second unidirectional communication path (R_4) from the object (12) to the second communication transceiver (11) so that the object (12) transmits the fourth ranging signal to the second communication transceiver (11) in response to the first ranging signal. 55

8. The system of claim 6, characterized in that the first communication transceiver (11) provides the first unidirectional communication path (R₃) from the first communication transceiver (11) to the object (12) so that the first communication transceiver (11) transmits the third ranging signal to the object (12) and the object (12) transmits a fifth ranging signal to the ground transceiver (13) in response to the third ranging signal and in that the second communication transceiver (11) provides the second unidirectional communication path (R₄) from the second communication transceiver (11) to the object (12) so that the second communication transceiver (11) transmits the fourth ranging signal to the object (12) and the object (12) transmits a sixth ranging signal to the ground transceiver (130) in response to the fourth ranging signal.

5

10

15

9. The system of claim 6, characterized in that the first communication transceiver (11) provides the second bidirectional communication path between the first communication transceiver (11) and the object (12) so that the first communication transceiver (11) transmits the third ranging signal to the object (12) and the object (12) transmits a fifth ranging signal to the first communication transceiver (11) in response to the third ranging signal and in that the second communication transceiver (11) provides the third bidirectional communication path between the second communication transceiver (11) and the object (12) so that the second communication transceiver (11) transmits the fourth ranging signal to the object (12) and the object (12) transmits a sixth ranging signal to the second communication transceiver (11) in response to the fourth ranging signal.

20

25

30

35

10. The system of claim 6, characterized in that the object (12) is an aircraft.

40

45

50

55

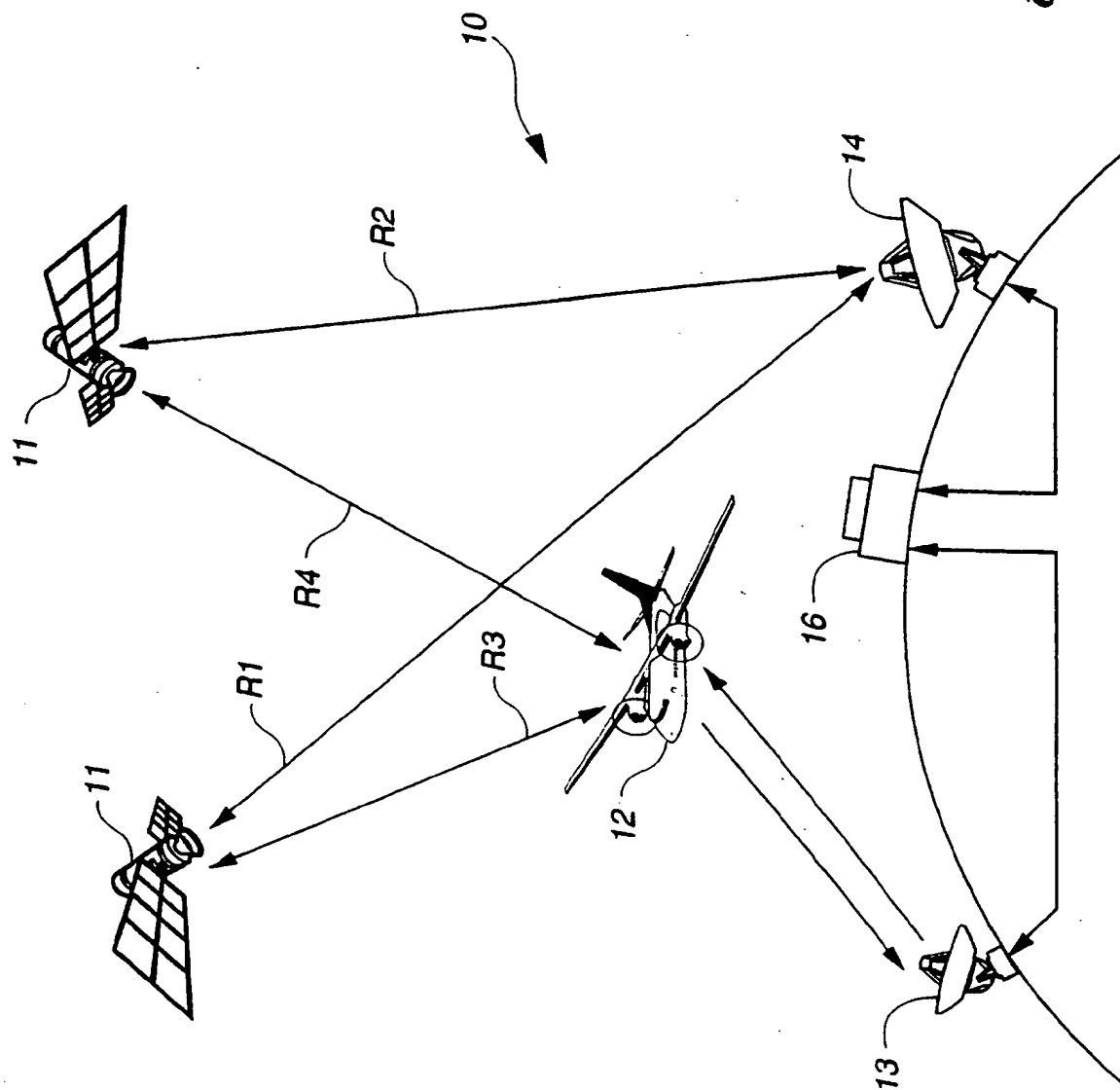
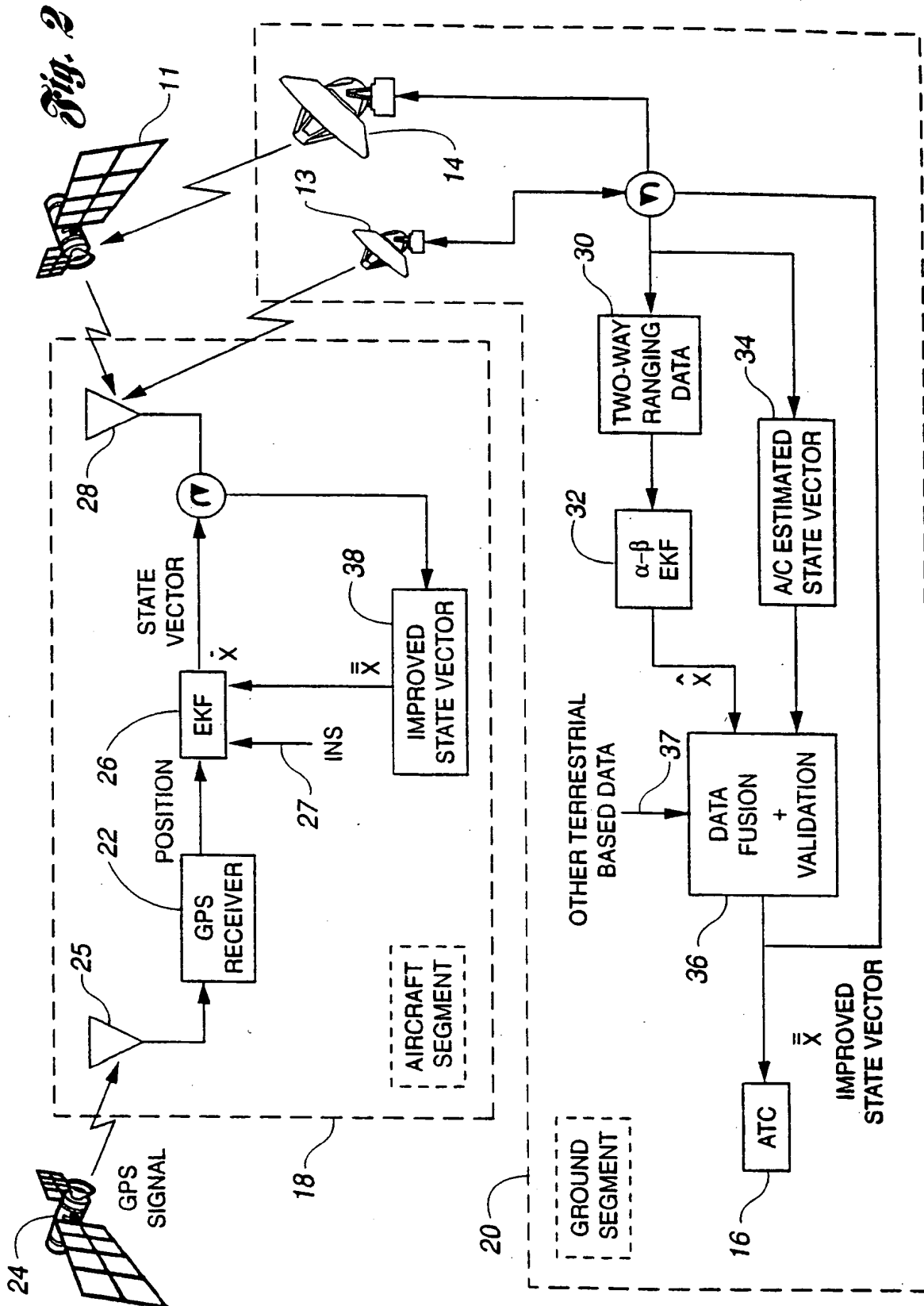

Fig. 1



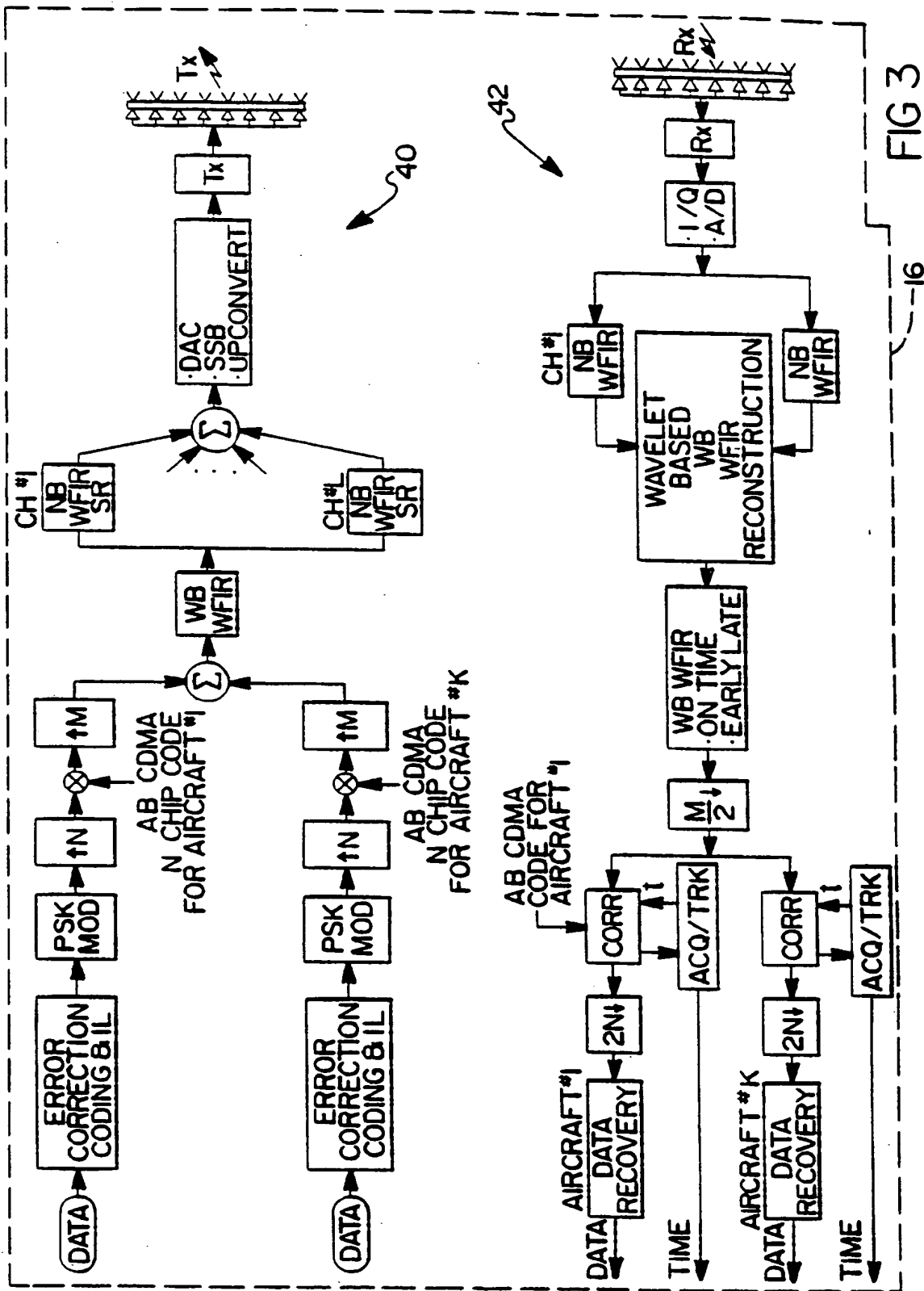
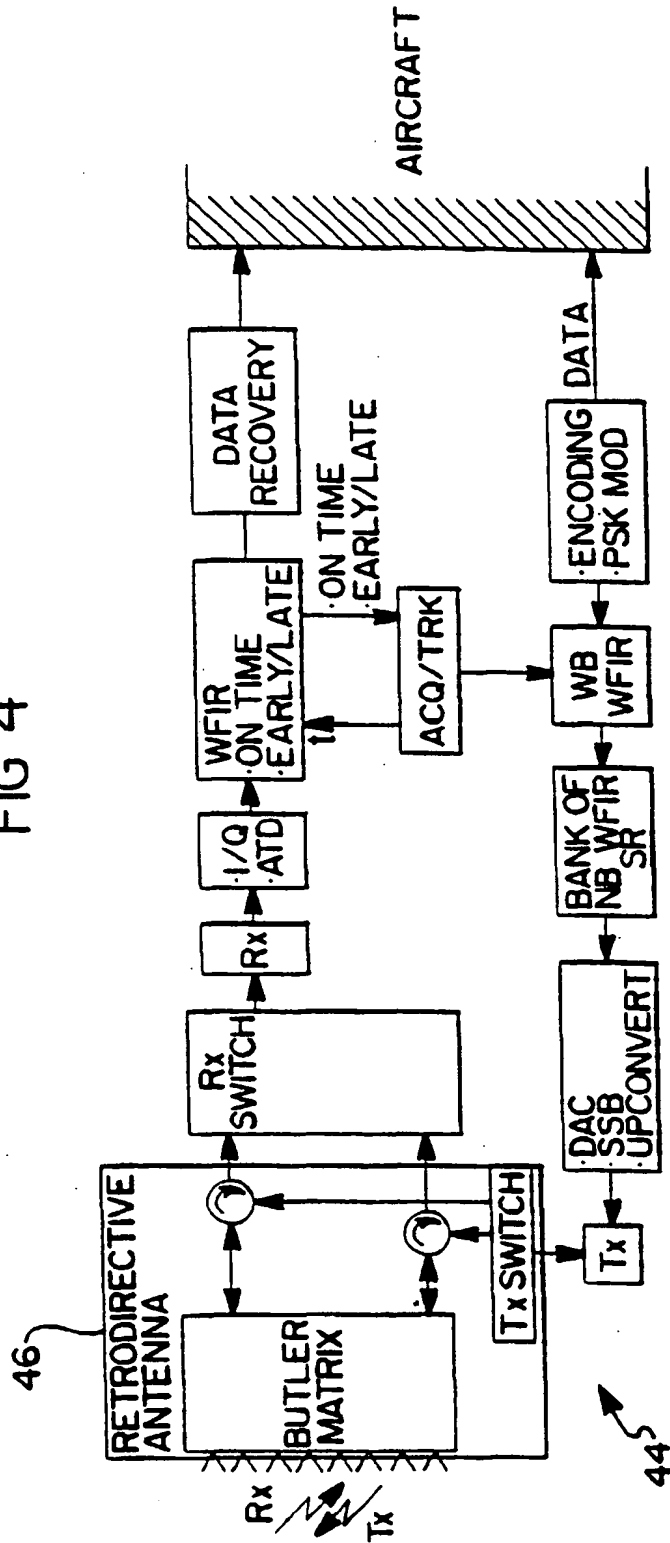
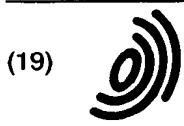

FIG 3

FIG 4



This Page Blank (uspto)



Europäisches Patentamt
European Patent Office
Office européen des brevets



(11) EP 0 860 708 A3

(12) EUROPEAN PATENT APPLICATION

(88) Date of publication A3:
29.09.1999 Bulletin 1999/39

(51) Int. Cl.⁶: G01S 5/02, G01S 13/87

(43) Date of publication A2:
26.08.1998 Bulletin 1998/35

(21) Application number: 98103057.0

(22) Date of filing: 21.02.1998

(84) Designated Contracting States:
AT BE CH DE DK ES FI FR GB GR IE IT LI LU MC
NL PT SE
Designated Extension States:
AL LT LV MK RO SI

- Yung, Kar W.
Signal Hill, CA 90806 (US)
- Novak, John I. III
Signal Hill, CA 90806 (US)
- Goliff, William
Signal Hill, CA 90806 (US)

(30) Priority: 21.02.1997 US 803935

(71) Applicant:
Hughes Electronics Corporation
El Segundo, California 90245-0956 (US)

(74) Representative:
Witte, Alexander, Dr.-Ing. et al
Witte, Weller, Gahlert, Otten & Steil,
Patentanwälte,
Rotebühlstrasse 121
70178 Stuttgart (DE)

(72) Inventors:
• Chang, Donald C.
Thousand Oaks, CA 91360 (US)

(54) Method and system for determining a position of a transceiver unit utilizing two-way ranging in a polystatic satellite configuration including a ground radar

(57) A method and system for determining the position of an object (12), such as an aircraft, utilizes two-way ranging with a polystatic satellite configuration and ground radar (13). A ground transceiver (13) at a first known location provides a bidirectional communication path between the ground transceiver (13) and the object (12) wherein the ground transceiver (13) transmits a first ranging signal to the object (12) and the object (12) transmits a second ranging signal to the ground transceiver (13) in response to the first ranging signal. A first communication transceiver (11) at a second known location provides a first unidirectional communication path (R₃) between the first communication transceiver (11) and the object (12) wherein the first communication transceiver (11) performs one of transmitting a third ranging signal to the object (12) and receiving a third ranging signal from the object (12) in response to the first ranging signal. A second communication transceiver (11) is arranged at a third known location for providing a second unidirectional communication path (R₄) between the second communication transceiver (11) and the object (12) wherein the second communication transceiver (11) performs one of transmitting a fourth ranging signal to the object (12) and receiving a fourth ranging signal from the object (12) in response to the

first ranging signal. A signal processor (13, 14, 16) determines a first, second and third path length, and determines the position of the object (12) based on the first, second and third known locations and the first, second and third path lengths.

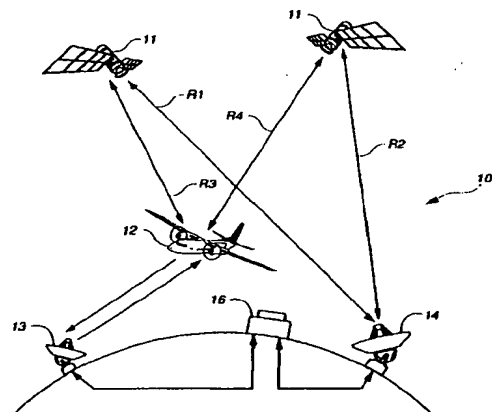

Fig. 1

EP 0 860 708 A3



European Patent Office

EUROPEAN SEARCH REPORT

Application Number
EP 98 10 3057

DOCUMENTS CONSIDERED TO BE RELEVANT			
Category	Citation of document with indication, where appropriate, of relevant passages	Relevant to claim	CLASSIFICATION OF THE APPLICATION (Int.Cl.6)
X	US 4 897 661 A (HIRAIWA HISAKI) 30 January 1990 (1990-01-30) * abstract; figures 1,2 * * column 1, line 59 - column 2, line 36 * * column 4, line 1 - line 47 * ---	1,2,6,7, 10	G01S5/02 G01S13/87
X	US 4 359 733 A (O'NEILL GERARD K) 16 November 1982 (1982-11-16) * abstract; figures 1,2 * * column 15, line 27 - line 35 * * column 16, line 22 - line 50 * * column 17, line 11 - line 30 * ---	1,2,6,7, 10	
X	EP 0 335 558 A (MARCONI CO LTD) 4 October 1989 (1989-10-04) * abstract; figure 1 * * column 2, line 12 - line 28 * ---	1,3,5	
A	US 5 006 855 A (BRAFF RONALD) 9 April 1991 (1991-04-09) * abstract; figure 2 * * column 2, line 66 - column 3, line 8 * * column 3, line 16 - line 28 * * column 5, line 9 - line 59 * -----	1,6	
			TECHNICAL FIELDS SEARCHED (Int.Cl.6)
			G01S
The present search report has been drawn up for all claims			
Place of search THE HAGUE		Date of completion of the search 5 August 1999	Examiner Niemeijer, R
CATEGORY OF CITED DOCUMENTS		T : theory or principle underlying the invention E : earlier patent document, but published on, or after the filing date D : document cited in the application L : document cited for other reasons ----- & : member of the same patent family, corresponding document	
X : particularly relevant if taken alone Y : particularly relevant if combined with another document of the same category A : technological background O : non-written disclosure P : intermediate document			

EPO FORM 1503 03.82 (P04C01)

**ANNEX TO THE EUROPEAN SEARCH REPORT
ON EUROPEAN PATENT APPLICATION NO.**

EP 98 10 3057

This annex lists the patent family members relating to the patent documents cited in the above-mentioned European search report. The members are as contained in the European Patent Office EDP file on
The European Patent Office is in no way liable for these particulars which are merely given for the purpose of information.

05-08-1999

Patent document cited in search report	Publication date	Patent family member(s)	Publication date
US 4897661 A	30-01-1990	JP 63253278 A	20-10-1988
		CA 1298387 A	31-03-1992
		DE 3852417 D	26-01-1995
		DE 3852417 T	27-04-1995
		EP 0287261 A	19-10-1988
US 4359733 A	16-11-1982	CA 1156339 A	01-11-1983
		DE 3152340 C	08-12-1983
		EP 0059755 A	15-09-1982
		WO 8201076 A	01-04-1982
EP 0335558 A	04-10-1989	GB 2215932 A	27-09-1989
		AU 3168789 A	28-09-1989
		FI 891413 A	27-09-1989
		JP 1298820 A	01-12-1989
		PT 90113 A	10-11-1989
US 5006855 A	09-04-1991	AU 7915987 A	08-03-1988
		DK 211788 A	11-05-1988
		WO 8801392 A	25-02-1988

EPO FORM P0459

For more details about this annex : see Official Journal of the European Patent Office, No. 12/82

This Page Blank (uspto)